

**MODERN METHOD OF APPLYING THE MIXTURE ON A VERTICAL SURFACE**

<sup>2</sup>**Galushko V.O.**, Doctor of Technical Sciences, Professor,  
dtn.gva@gmail.com, ORCID: 0000-0001-5744-0486

<sup>1</sup>**Meneilyuk O.I.**, Doctor of Technical Sciences, Professor,  
meneilyk@gmail.com, ORCID: 0000-0002-1007-309X

<sup>1</sup>**Bichev I.K.**, Ph.D., Associate Professor,  
bichev@ukr.net, ORCID: 0000-0002-3000-2600

<sup>1</sup>**Kyryliuk S.V.**, Ph.D.,  
kirilstani@ukr.net, ORCID: 0000-0002-8871-8302

<sup>1</sup>**Uvarov D.Yu.**, acquirer,  
s21uvarov@ogasa.org.ua, ORCID: 0000-1000-2135-9113-42X

<sup>3</sup>**Uvarova A.S.**, student,  
nastya.pidoyma@gmail.com, ORCID: 0000-0002-1416-7181

<sup>1</sup>*Odesa State Academy of Construction and Architecture*  
St. Didrichsona, 4, Odesa, 65029, Ukraine

<sup>2</sup>*Donbas National Academy of Construction and Architecture*  
St. Karpatska, 15, Ivano-Frankivsk, 76019, (temporary), Ukraine

<sup>3</sup>*Khortytsk National Educational and Rehabilitation Academy*  
St. 59, Naukovo Mischechka, Zaporizhzhia, 69017, Ukraine

**Abstract.** When applying mixtures to a vertical surface, it is not always possible to use stationary equipment. This includes scaffolding, cradles, aerial work platforms, and, for small volumes, installation climbers. The mixture is usually applied with a roller, brush or spray gun. These methods lead to excessive consumption of the mixture, increased work time, and often a lack of safety precautions. Working at height is very dangerous, especially in the current environment. Therefore, both in our country and abroad, scientists are developing new alternatives to manual, semi-manual and mechanised methods. One of these mechanisms is automation and robotics. The task of the workers is to control the work processes, monitor the supply of materials and replace equipment as necessary. Such mechanisms are operated by up to three workers.

Having studied all the available information, the authors proposed to use the Portal equipment to perform a range of works at height. It will allow you to perform work on slopes, terraces, and hard-to-reach places. To do this, you need to make a small terrace, level the surface, mount the rails, and install the Portal. Then, using additional mechanisms, the equipment is attached. In the first stage, augers are used to drill a well into which the reinforcement is installed, and the concreting process is carried out using various removable devices (winches, drills, etc.) that are attached to the Portal.

In the second stage, the ground is excavated, and the pile is exposed by 3.6 metres. In the third stage, a wooden formwork is placed between the piles. The frame is partially attached to the pile, and the outer side of the formwork is mounted. The concreting process is carried out sequentially. First, the lower part is concreted, and then the upper part. In the fourth stage, the mixture is applied to the surface.

The article presents and analyses the results of laboratory studies of the operation of the Portal equipment with a device for intensifying the injection of a flowing mixture. The following schemes were considered when choosing the technology of mixture injection: perpendicular-straight-line, perpendicular-circular and inclined-straight-line. The optimal combinations of layer thickness and the angle of inclination of the nozzle axis to the surface and technological schemes of application are given.

**Keywords:** mixture application, automation and robotisation, Portal equipment, slope protection, wall in the ground.

**Introduction.** When applying mixtures to a vertical surface, it is not always possible to use stationary equipment. This is primarily due to the danger of working at height. For small volumes and small areas, installation climbers are used. There is a need to monitor both the work performed and compliance with safety regulations. Therefore, many national and international scientists are developing alternative equipment and methods for performing such work.

**The analysis of the latest research and publications is following.** In the past, the mix was usually applied to vertical surfaces with rollers, brushes or sprayers, using scaffolding, cradles or climbers (depending on the height of the wall enclosure). These methods were expensive, labor-intensive and dangerous. In addition, they were life-threatening to the operator, so many domestic and international scientists are developing alternatives to perform these tasks at a minimal cost. One such alternative is robotisation [1].

Robotisation is progressing in the manufacturing industry. Worldwide, the popularity of robots is growing exponentially. This growth is also accompanied by large-scale investments in research and development in the field of robotics. In recent years, there has been a growing demand for the use of robots and automated machines and systems in the construction process [2].

The domestic specialists and scientists engaged in this area are O.I. Meneilyuk, V.O. Halushko, A.F. Petrovskiy, I.A. Yemelyanova, D.O. Chaika and others [3-5] as well as foreign scientists - Scott Peters, Mark Pivac, Markus Kayser, Nery Oxman, Joseph Paradiso, Daniela Rus, Nikita Chen-Yun-Tai, etc. [6-8]. They are engaged in automation and robotics of production processes and mathematical modelling for automation in various areas of industrial and construction products. With the help of automation, you can reduce the duration of work and increase production productivity, quality and safety of work. Based on the received information, the Portal was developed, which provides the opportunity to perform work in automatic mode on the construction site.

**The purpose and objectives of the research** of this article are to develop a mechanism that will allow performing work at altitude and slopes qualitatively and more safely.

The task of the research is to analyse the existing methods of application on a vertical surface and offer its technology.

**The materials and methods of the research are following.** Currently, there are the following ways to perform work on restoring the vertical surfaces, ref. to Table 1.

Table 1 – Ways to perform work

Name of the method of work performance	Use of a cost-effective method for damaged vertical surfaces		
	low – height up to 10 metres	middle – height from 10 to 20 metres	high – height over 20 metres
	new / destruction on the surface	new / destruction on the surface	new / destruction on the surface
From the ground (preparatory work)	+/-	-	-
From scaffolds	++	++	++
From cradles	--	-/+	-/+
From lift truck	-/+	-/+	-/+
By industrial climbers	-/+	+/-	+/-

The analysis of the table results showed that applying the mixture to a vertical surface from the ground will be more efficient up to 2 m, and then it is necessary to choose lift trucks, scaffolding, and industrial climbers – depending on the volume. For surfaces with a height of 10 to 20 m, it is more efficient to use scaffolding, lift trucks and industrial climbers. For floors over 20 m, scaffolding and lift trucks are used. This, in turn, leads to an increase in the cost of work. Therefore, the authors developed the Portal equipment, which may be an alternative in the future.

It includes two units. The first unit is the main unit, which provides autonomous operation, and the second unit is a semi-unit that can be extended to the first unit and cannot operate autonomously. There may be several such semi-units depending on the length of the facility (Fig. 1).

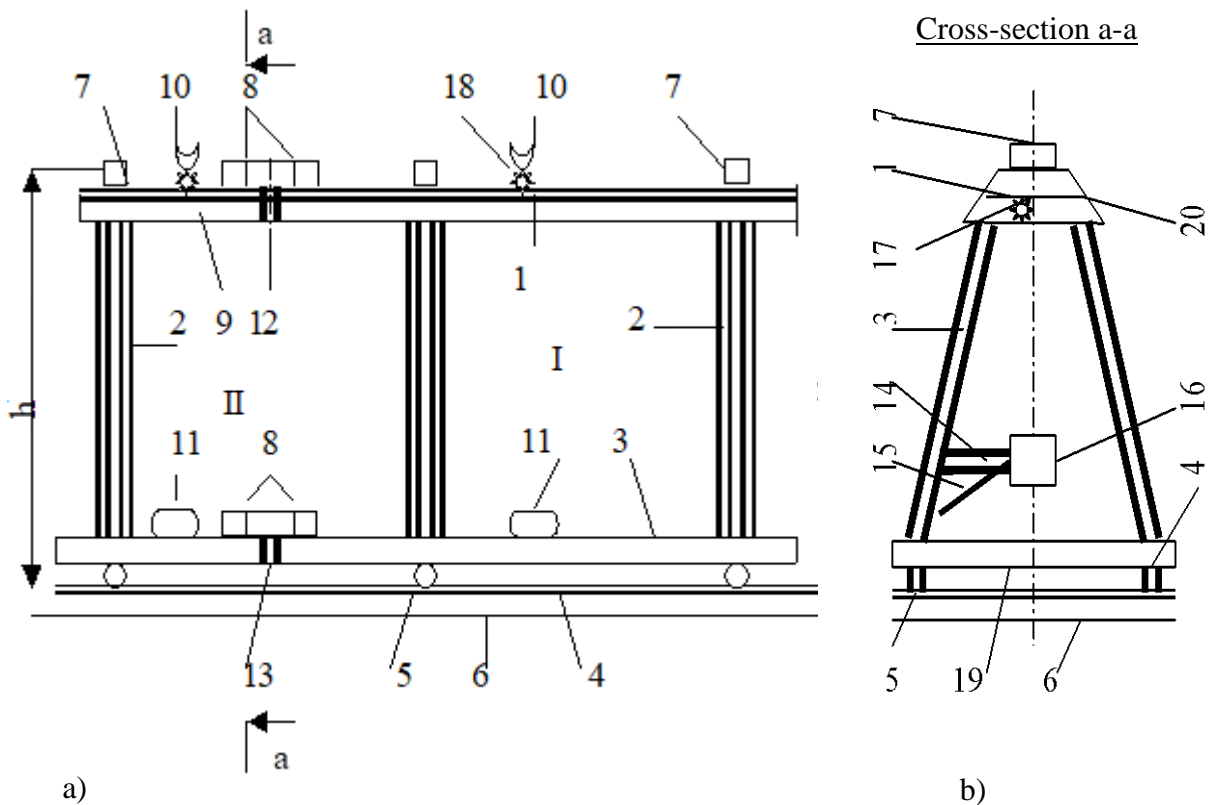

Fig. 1. Equipment for strengthening ground and foundations and for performing pile foundations for strengthening slopes: a – general appearance; б – cross-section by "a-a" of the Portal  
 1 – portal; 2 – rack; 3 – connecting shelf; 4 – rail; 5 – wheel; 6 – ties; 7 – jacks; 8 – connecting bar; 9 – semi-portal; 10 – graduated guide element; 11 – clamps to hold the auger or pile during the extension process; 12 – hinged connection of the Portal; 13 – hinged connection of the Portal; 14 – console; 15 – brace; 16 – screw clamp; 17 – winch; 18 – trolleys; 19 – lower reinforcing shelf of the anchor element; 20 – upper reinforcing shelf of the anchor element

The Portal [9] is an autonomous frame and a half-frame, including a longitudinal span (portal) – 1; racks – 2, which are installed vertically with an inclination to ensure a more stable state, forming an anchor element; connecting shelf – 3, which provides a rigid connection of two oppositely located end anchor elements, and the anchor elements themselves have reinforcing shelves, respectively, lower – 4; upper – 5; half-portal – 6.

For free movement around the work site, the Portal has wheels – 7 in the form of articulated joints and rails – 8, which are laid on the floor. The rails – 9 can be laid on sleepers to reduce the loads – 9.

In the upper part of the Portal, at specially defined points, plates are rigidly welded on which portable screw jacks are installed – 10. The joint operation of the main unit and the semi-unit is ensured by a hinged connection – 11, 12 with the help of connecting strips – 13.

The Portal is equipped with a movable graduated element in the form of a toothed hemisphere – 14, on the trolleys – 15, on which both the first block and the other block can be equipped with devices for piling. The next step is to change the retaining wall devices. The following equipment is attached to the Portal: grab, winch, etc.

Due to the work that can be carried out at different heights, the Portal is made in the form of various structural elements being built up. With the help of additional mechanisms, it is multifunctional. The device is used to intensify the injection of the flowing mixture to apply the mixture to a vertical surface.

Holding on to the weight of the device for intensification of the fluid mixture is carried out using grips – 16 with clamp – 17, which are attached to the console – 18 with a brace – 19.

Rigging is carried out using a winch – 17, with stops that include a ratchet wheel, shaft, pawl, axle, spring, various types of grip, etc. These devices do not prevent the lifting of the load but

exclude the possibility of its spontaneous descent under the influence of its weight.

For the manufacture of structures using steel alloys, following current standards for specific elements as to the operating conditions.

The Portal works this way. For most current performing work, most often, the work is carried out on the slopes, and a terrace is performed. After levelling the surface, the rails on which the Portal is installed are mounted. In the first stage, using screws, drilling of the well into which the reinforcement is installed is carried out, and the concreting process is carried out using various detachable devices (winches, drill, etc.) that are attached to the Portal.

In the second stage, the soil is developed, and the pile is exposed by 3.6 meters. In the third stage, a wooden formwork is arranged between the piles. The frame is partially attached to the pile, and the outer side of the formwork is mounted. The concreting process is carried out sequentially. First, the lower part is concreted, and then the upper part. In the fourth stage, the mixture is applied to the surface (Fig. 2).



a – drilling process



b – concreting of a pile



c – soil development



d – general view of piles



e – concrete foundation is performed



f – installation of internal formwork and reinforcing frame

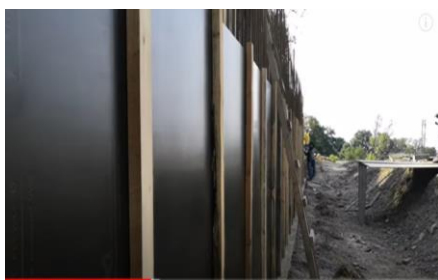

g – general view of the formwork



h – concreting process



i – general view of the retaining wall

Fig. 2. Technological sequence of performing a vertical retaining wall

This Portal [9] has an advantage over well-known equipment in that:

- it provides an increase in labour productivity and complex mechanisation of production processes, reduced capital costs, which makes it possible to increase the operational suitability of structures;

- the structural elements of the main supporting equipment Portal are mass-produced, which provides installation of elements manually, without mechanisms;
- when switching to another parking lot, the entire complex of the mechanisation device does not require dismantling and installation during operation due to the possibility of moving its assembly along rails or additional extension of half-blocks;
- the presence of a hinge connection of the block and the half-block allows performing work on a break;
- the combination of a block and a half-block ensures the execution of work simultaneously on several grippers;
- due to the possibility of trailed equipment, several processes are ensured when performing a retaining wall.

Further development of the theory and practice of modern methods of work in compressed, space-limited conditions of operated structures and their reconstruction is achieved.

**Research results.** When applying the mixture to a vertical surface, the device is attached to the gantry. The upper part of the gantry frame has fasteners that allow the nozzle to move from top to bottom without changing the path [10].

The following is a device that can be used to perform work at height. Namely: cleaning the surface, priming and applying the mixture (Fig. 3).

The dry mixture of the appropriate composition is fed through a branch pipe – 1, which has a hinged ball joint – 3 or a rigid connection with a hollow shaft – 7 and further into the body – 2, on which a forward auger – 4 and a reverse auger – 5 are freely mounted, which start to rotate in different directions, and special spacer retainers – 6 ensure their design position, at the same time, the hollow shaft – 7 rests on plugs – 9, which are limit cases – 2.

The dry mixture is gradually moved to the humidification zone, where water is supplied through holes – 8, which are located on a certain section of the shaft – 7. Further, under the action of acceleration, the moistened mixture is moved to the reverse action auger – 5, which is fed to the corresponding part of the structure. To regulate the amount of mixture supplied, the nozzle – 10 has a set of gate valves – 11, which are replaced and accordingly increase or decrease the opening and the amount of mixture supplied.

At the same time, to increase the speed of feeding the appropriate mixture, the nozzle – 10 is installed perpendicular to the axis of the hollow shaft – 7.

These technical features ensure the use of the proposed technical solution in construction based on the following advantages:

- improved quality of intensification of the spray mixture;
- it becomes possible to adjust the quantity, and hence the speed of feeding the mixture by using one of the gate valves;
- the operational suitability that provides such a "Device ..." compliance with the criterion "Industrial suitability" is increased.

This goal is achieved by the fact that the utility model "Device for intensification of fluid injection" is based on the task, which is based on the known technical solution "Device for spraying a fluid mixture", replacing the purpose of some elements by constructive changes and adding new elements and ensuring their interaction. By working together, it became possible to create the corresponding "Device..." namely, a cylindrical body limited by plugs in the centres of which a hollow shaft is hinged or rigidly mounted, on which mixing elements are fixed, freely rotating in different directions, and equipped with spacers, the so-called direct and reverse action, creating conditionally active zones of activation and moistening, in a certain area in the humidification zone, the hollow shaft has through holes and is ball-and-socket or rigidly connected to the mixture supply pipe, and the nozzle in the form of a conical cross-section is mounted perpendicular to the axis of the hollow shaft and is provided with a set of certain gate valves [10, 11].

New in the invention is the use of mixing elements that freely rotate in different directions simultaneously and the placement of the nozzle perpendicular to the axis of the hollow shaft.

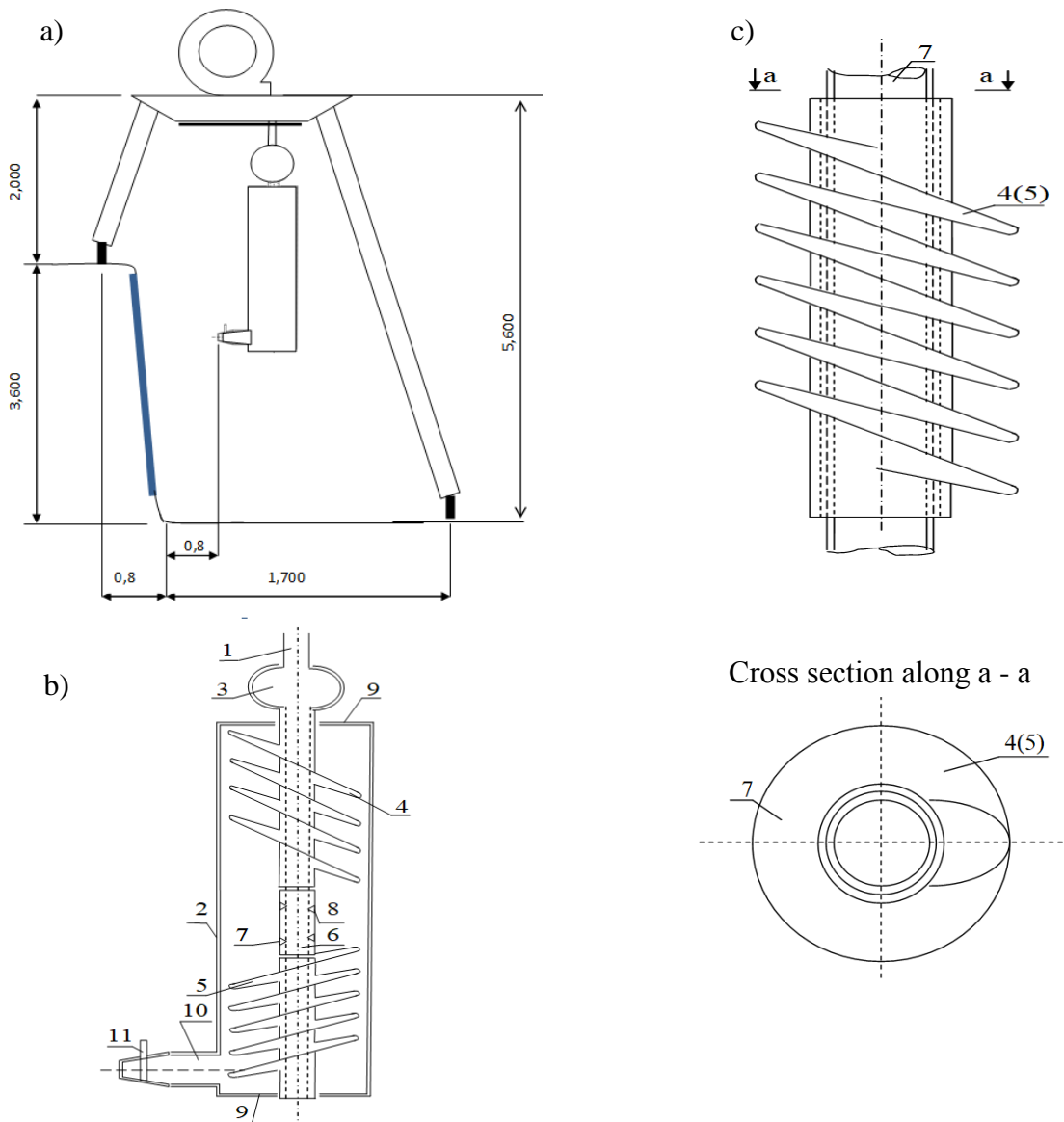

Fig. 3. Device for intensification of fluid mixture ejection:

- a – general view of the equipment; b – device; c – auger; 1 – mixture supply branch pipe; 2 – body; 3 – hinged ball joint; 4 – forward auger; 5 – reverse auger; 6 – spacer retainer; 7 – hollow shaft; 8 – through-holes; 9 – plug; 10 – nozzle; 11 – gate valve

The following results were obtained during laboratory tests: the distance from the nozzle to the vertical surface ranged from 0.8 to 1.2 m, while the amount of mixture rebound ranged from 17.2 to 16.4%.

Based on the results obtained, a graph of the dependence of the strength of the mixture and the number of losses on the angle of inclination of the nozzle to the surface was constructed (Fig. 4).

The analysis of Fig. 4 shows that the strength of the mixture and the number of losses depend on the angle of inclination of the nozzle and the thickness of the layer to be placed. At a mixture layer thickness of 50 mm and an inclination angle of 15° to 25°, the amount of losses reaches a minimum level of 8.5 to 9.5%, and the tensile strength is between 37 and 39 MPa. In engineering terms, this angle of inclination is optimal in terms of the criteria for assessing the strength of the mixture with the surface and the amount of mixture loss.

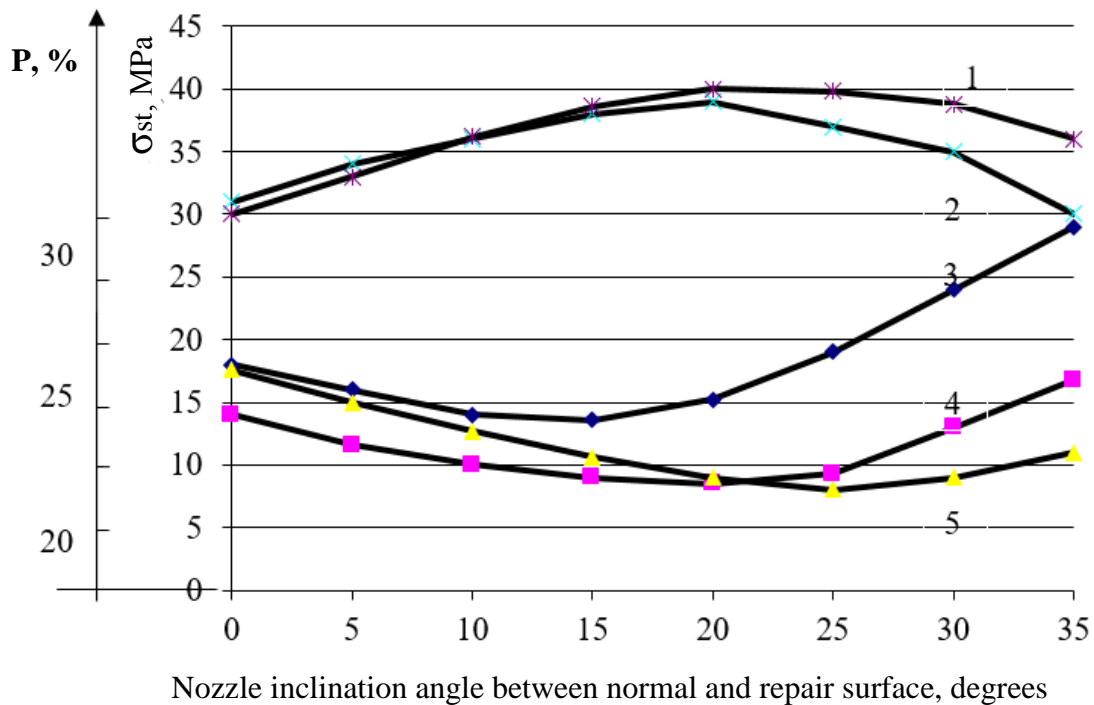

Fig. 4. Diagram of the dependence of the strength of the mixture and the number of losses on the angle of the nozzle to the vertical surface:

1, 2 – compressive strength limit,  $\sigma_{st}$ , MPa; 3, 4, 5 – quantity of losses, P, %, (3 – layer strip thickness of 30 mm; 1, 4 – mixture layer strip thickness of 50 mm; 2, 5 – layer strip thickness of 80 mm)

The following schemes were considered when choosing the technology for supplying the mixture: perpendicular-straight, perpendicular-circular and inclined-straight. For these schemes, the optimal combinations of concrete mix application were selected: with perpendicular-straight – nozzle angle 90-layer thickness 30 mm. At least two layers should be applied in a circular rotation. This is due to the perpendicular-circular movement, as the layers are unevenly laid on the surface. Therefore, by applying two coats, a uniform application thickness of 50 mm can be achieved. For oblique-rectilinear movement, the optimal angle of inclination is 20° and a thickness of 80 mm. In this case, the amount of loss is minimal. The particles of the mixture penetrate deeply into the surface, so the maximum strength.

Table 2 shows the optimal combinations of the layer thickness and the angle of inclination of the nozzle axis to the surface and the technological schemes of application.

Table 2 – Optimal combinations

No.	Technological schemes	The thickness of the applied layer, mm	The angle of inclination of the nozzle from normal to the surface of the structure, °
1	perpendicularly straight	30	90
2	perpendicularly circular	50	90
3	inclined and straight	80	20

The analysis of various methods showed that the most appropriate organisation of the technological process of laying concrete mixture is the method of supplying concrete using the proposed installation [9, 10]. This installation is compact and occupies a small place. This allows you to increase productivity and perform work efficiently, as workers have the opportunity to move freely in the room where the work is performed.

**The conclusions and prospects for further research are following.** The offered "Portal" equipment makes it possible to perform several technological processes. Namely: drilling, installation, concreting, cleaning and application of the mixture on a vertical surface due to the change of equipment. This will reduce the time, cost of work, improve the quality of work and reduce the risk of workers working at height.

### References

- [1] A. Zhu, P. Pauwels, B. De Vries, "Component-based robot prefabricated construction simulation using IFC-based building information models", *Automation in Construction*, 152, 104899, 2023. <https://doi.org/10.1016/j.autcon.2023.104899>.
- [2] C.D. Atkinson, F. Aslani, "Performance of 3D printed columns using self-sensing cementitious composites", *Construction and Building Materials*, 375, 130961, 2023. <https://doi.org/10.1016/j.conbuildmat.2023.130961>.
- [3] Valentyna Halushko, Alexander Meneilyk, Anatolii Petrovskiy, Denys Uvarov, Anastasiia Uvarova, "Development of technology of mixture application on vertical surface", *Technology Audit And Production Reserves*, vol. 2, no. 1(64), pp. 6-10, 2022. DOI: 10.15587/2706-5448.2022.257050. <http://journals.uran.ua/tarp/issue/view/15443>.
- [4] O. Meneilyuk, A. Petrovskiy, O. Borisov, S. Kyrlyuk, "Development of device technology anti-filtration screen with use screw equipment", *Economic and Social Developmen - 32nd International Scientific Conference on Economic and Social Development*, 2018. <https://www.proquest.com/openview/6c5eb6e77f622e24c43a78d15b000801/1?pq-origsite=gscholar&cbl=2033472/>.
- [5] I.A. Emeljanova, D.O. Chayka, V.O. Bondar, V.V. Virchenko, "Concrete pump working capacity determination in the composition of small-sized technological set equipment for the wet method gunite work", *Industrial Machine Building, Civil Engineering*, no. 2 (51), pp. 166-179, 2018. <https://doi.org/10.26906/znp.2018.51.1310>.
- [6] S. Ercan Jenny, L.L. Pietrasik, E. Sounigo, E. Lloret-Fritschi, M. Hutter, "Continuous Mobile Thin-Layer On-Site Printing", *Automation in Construction*, 146, 104634, 2023. <https://doi.org/10.1016/j.autcon.2022.104634>.
- [7] M. Kayser, L. Cai, S. Falcone, B. Darweesh, N. Oxman, "Freeform Design of a multi-agent, fiber composite digital fabrication system", *Science Robotics*, 3(22), 5630, 2018. <https://www.science.org/doi/10.1126/scirobotics.aau5630>.
- [8] V. Sumini, M. Muccillo, J. Milliken, A. Ekblaw, J. Paradiso, "SpaceHuman: A soft robotic prosthetic for space exploration", *Conference on Human Factors in Computing Systems - Proceedings*, 2020. <https://dl.acm.org/doi/10.1145/3334480.3383087>.
- [9] V.O. Halushko, Portal dlia vykonannia remontno-vidnovliuvalnykh robit. Patent na korysnu model no. 45279 U; zaiavl. 21.05.2007; Opubl. 10.11.2009, Biul. no. 21.
- [10] O.I. Meneiliuk, V.A. Halushko, O.M. Halushko, M.M. Donchenko, Prystrii dlia intensyfikatsii napryskuvannia tekuchoi sumishi. Patent na korysnu model no. 101756 U; zaiavl. 20.04.2015; Opubl. 25.09.2015, Biul. No. 18.
- [11] I. Barabash, D. Harashenko, "Mechanoactivation of Portland cement in the technology of manufacturing the self-compacting concrete", *Eastern-european journal of enterprise technologies*, no. 3/6 (93), pp. 12-17, 2018.



## СУЧАСНИЙ СПОСІБ НАНЕСЕННЯ СУМІШІ НА ВЕРТИКАЛЬНУ ПОВЕРХНЮ

<sup>2</sup>Галушко В.О., д.т.н., професор,  
dtn.gva@gmail.com, ORCID: 0000-0001-5744-0486

<sup>1</sup>Менейлюк О.І., д.т.н., професор,  
meneilyk@gmail.com, ORCID: 0000-0002-1007-309X

<sup>1</sup>Бічев І.К., к.т.н., доцент,  
bichev@ukr.net, ORCID: 0000-0002-3000-2600

<sup>1</sup>Кирилюк С.В., к.т.н.,  
kirilstani@ukr.net, ORCID: 0000-0002-8871-8302

<sup>1</sup>Уваров Д.Ю., здобувач,  
s21uvarov@ogasa.org.ua, ORCID: 0000-1000-2135-9113-42X

<sup>3</sup>Уварова А.С., студентка,  
nastya.pidoyma@gmail.com, ORCID: 0000-0002-1416-7181

<sup>1</sup>Одеська державна академія будівництва та архітектури  
вул. Дідріхсона, 4, м. Одеса, 65029, Україна

<sup>2</sup>Донбаська національна академія будівництва і архітектури  
вул. Карпатська, 15, м. Івано-Франківськ, 76019, (тимчасово), Україна

<sup>3</sup>Хортицька національна навчально-реабілітаційна академія  
вул. Наукового містечка, 59, м. Запоріжжя, 69017, Україна

**Анотація.** При нанесенні сумішей на вертикальну поверхню не завжди можливо використовувати стаціонарне обладнання. А саме: риштування, люльки, автовишки, та при невеликих об'ємах запрошують монтажних альпіністів. Нанесення суміші виконується зазвичай валиком, пензлем або фарбопультотом. Ці способи призводять до перевитрати суміші, збільшення тривалості роботи, і часто не дотримання техніки безпеки. Виконувати роботи на висоті дуже небезпечно, а особливо у сучасних умовах. Тому, як у нашій країні, так і за кордоном, вчені розробляють нові альтернативи ручному, напівручному та механізованому способам. Одним з таких механізмів є автоматизація та роботизація. Завданням робітників зводиться до того, щоб контролювати процеси виконання робіт, стежити за поданням матеріалу та в міру необхідності замінювати обладнання. Такі механізми обслуговують до трьох робітників.

Вивчивши всю наявну інформацію, автори запропонували для виконання комплексу робіт на висоті використовувати обладнання «Портал». Воно дозволить виконувати роботи, на схилах, терасах, важкодоступних місцях. Для цього потрібно зробити невелику терасу, вирівняти поверхню, змонтувати рейки, та встановити портал. Далі за допомогою додаткових механізмів кріпляться обладнання. На першому етапі за допомогою шнеків виконують буріння свердловини, в яку встановлюють арматуру, та виконується процес бетонування, за допомогою різних знімних пристроїв (лебідки, бура, та інші), які кріпляться до порталу.

На другому етапі розробляється ґрунт і паля оголюється на 3,6 метри. На третьому етапі між палями влаштовується дерев'яна опалубка. Каркас частково кріпиться до палі та монтується зовнішня сторона опалубки. Виконується процес бетонування послідовно. Спочатку нижня частина бетонується, а потім верхня. На четвертому етапі виконується нанесення суміші на поверхню.

Приведені та проаналізовані результати лабораторних досліджень роботи обладнання «Портал» з пристроєм для інтенсифікації напіскування текучої суміші. При виборі технології подачі суміші розглядалися такі схеми: перпендикулярно-прямолінійне, перпендикулярно-кругоподібне та похило-прямолінійне. Наведено оптимальні поєднання товщини шару та кута нахилу осі сопла до поверхні та технологічні схеми нанесення.

**Ключові слова:** нанесення сумішей, автоматизація та роботизація, обладнання «Портал», захист схилів, стіна в ґрунті.

Стаття надійшла до редакції 10.05.2023